

Bar feeder 01



Control 02

Vegamatic Pusher T

Cutting-off centre

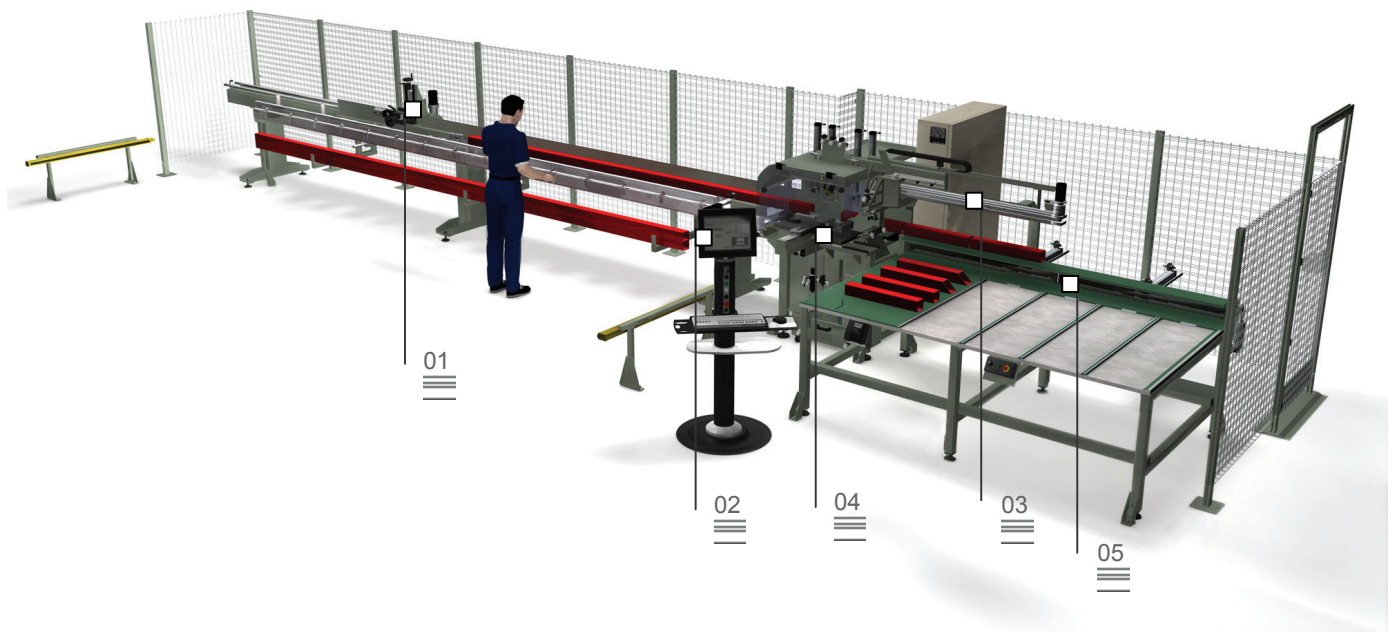

Automatic CNC cutting-off centre with horizontal blade feed, 3 controlled axes, designed for cutting profiles made of aluminium, PVC, light alloys in general. It performs automatic cutting according to predefined and optimized cutting lists. It can perform the bevelled cut on both sides of the profile. The machine is intended to perform cutting at an angle from 45° to 135°, manual loading and is equipped with an automatic unloading magazine on the opposite side. It can be fitted with customised horizontal and vertical drilling units for specific automatic machining operations.

Ejector 03

Cutting-off module 04

Unloading magazine 05

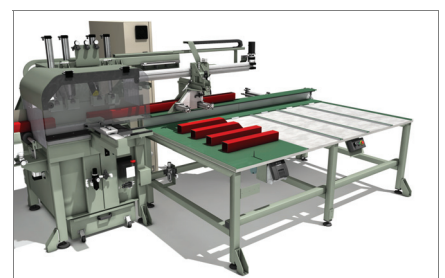
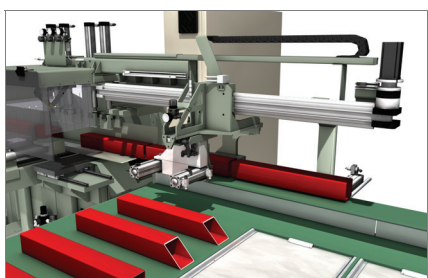

Vegamatic Pusher T

Cutting-off centre

01 Bar feeder

The CNC numerical control system for bar positioning, which is extremely quick and accurate, is complete with a gripper to clamp the profile and has provision for manual adjustment. Motion is transmitted by means of a rack and a low-backlash reduction gear to maintain the high standards of precision guaranteed by the CNC. The feeder runs on recirculating ball sleeves along casehardened bars.

02 Control

The operator interface with 15" touchscreen display has a network connection, USB ports and a floppy disk drive for communicating with external devices. It also has a built-in control panel, mouse and keyboard, and is preset for iButton and the installation of a label printer and connection to a remote control panel. The control is managed by the Windows 2000 operating system under which the Job and Blade software packages are installed: Job is designed for the job editor and optimizing cutting lists, Blade, installed alongside Job, controls the machine's operations and manages the machining processes.

03 Ejector

The ejector controlled by the CNC grips the workpiece during machining and, once completed, shifts it from the cutting area to the unloading magazine, holding it in the same position so as to facilitate the subsequent machining phases. Motion is transmitted by means of a toothed belt and secure gripping of the workpiece is ensured by pneumatic cylinders.

04 Cutting-off module

The cutting module consists of a single head cutting-off machine with hydro-pneumatic blade feed. It is provided with a 550 mm blade featuring wide cutting range: from 45° to 135°. Setting of the cutting angles is fully automatic and is handled by the CNC.

05 Unloading magazine

The workpiece unloading magazine has an automatic tilting and moving system that enables machining to be performed continuously, thus reducing the cycle time. In addition, the magazine allows finished workpieces to be stacked while a sensor, which emits a signal when the magazine is full, supervises system operation.

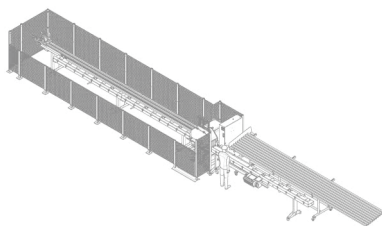

VEGAMATIC

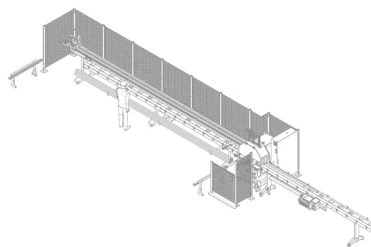

VEGAMATIC PUSHER

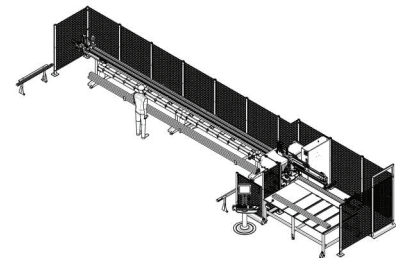

VEGAMATIC PUSHER T

AXIS TRAVEL	
U AXIS (feeder) (mm)	7.710
X AXIS (mm)	1.000
B AXIS (angle of blade)	45° ÷ 135°
MACHINING CAPACITY	
Max. loadable profile length	7.000
Theoretical minimum cutting length (mm)	0
Max. profile length that can be unloaded automatically (mm)	2.500
BLADE	
Diameter	550
Hydro-pneumatic feed	•
CUTTING AREA GUARD	
Full guard, pneumatically operated	•
LUBRICATION SYSTEM	
Spray-mist lubrication with oil emulsion	•
CLAMPS	
Vertical pneumatic clamps	3
Horizontal pneumatic clamps with pressure reducer plus pressure gauge	1
Clamp pressure reduction with pressure gauge	•
MOTOR	
Power rating (kW), three phase blade drive motor	3
PROVISION FOR SWARF EXHAUSTER	
MG4-MG8	optional